

BG	ТАВАНСКИ СЪЛБИ	LV	BĒNIŅU KĀPNES
CZ	PŮDNÍ SCHODY	NL	ZOLDER/VLIERINGTRAP
DE	BODENTREPP	PL	SCHODY STRYCHOWE
EE	PÕÕNINGUREDEL	PT	ESCADA DE SOTAO-ENCAIXADA
ES	ESCALERAS ESCAMOTEABLES	RO	SCARĂ MODULARĂ
FR	ESCALIER ESCAMOTABLE	RU	ЧЕРДАЧНАЯ ЛЕСТНИЦА
GB	LOFT LADDER	SI	PODSTREŠNE SLOPLJIVE STOPNICE
HU	PADLÁSFELJÁRÓ LÉPCSŐ	SK	STROPNÉ SKLÁPACIE SCHODY
IT	LE SCALE PER LA SOFFITTA	UA	СХОДИ НАГОРИЩЕ
LT	PALĖPĖS LAIPTELIAI		

LWS

LWK

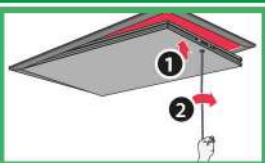
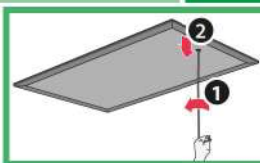
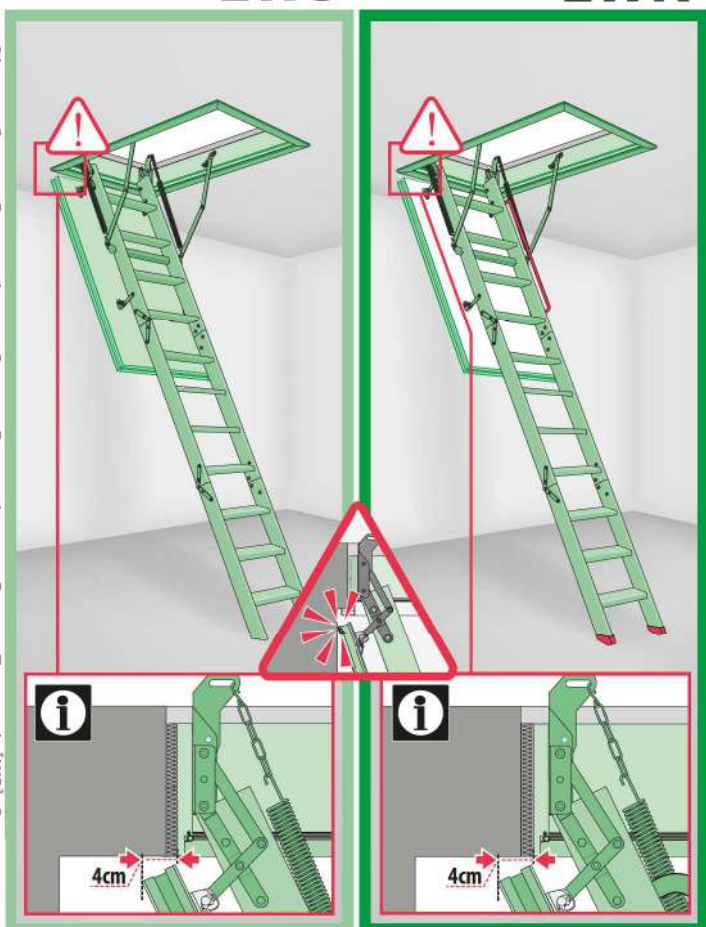

<http://www.fakro.com/download/film-installation-instructions/loft-ladders/>

READ SAFETY INSTRUCTION BEFORE USING



NC 9CE



WARNING!



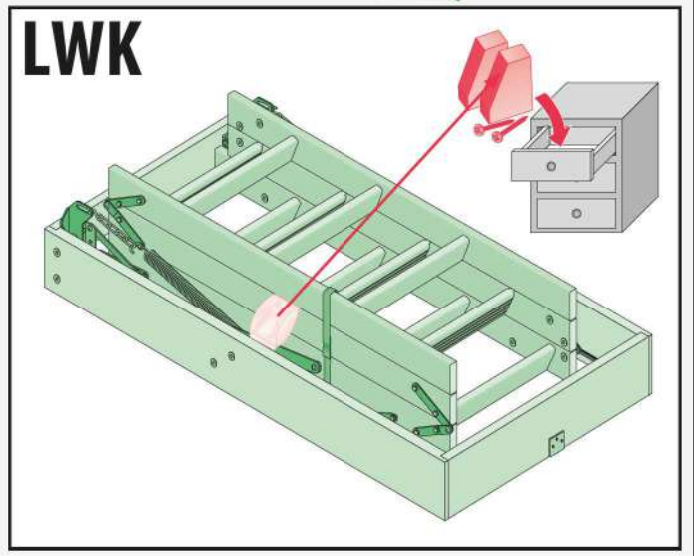
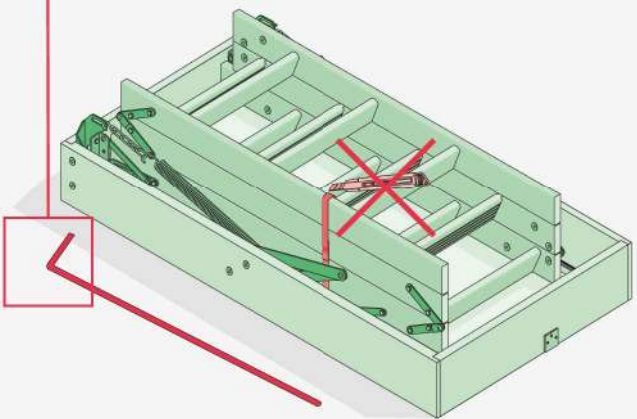
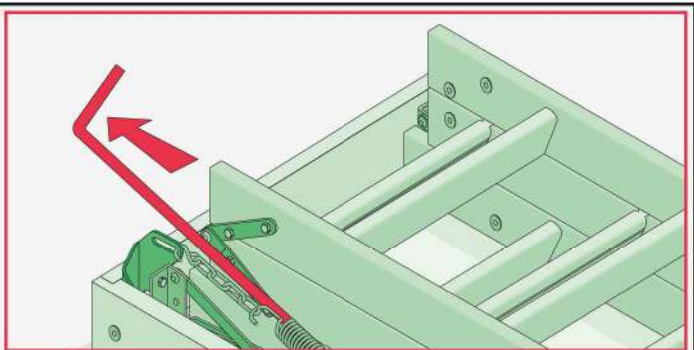
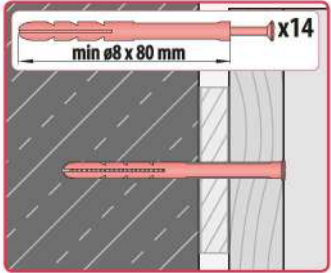
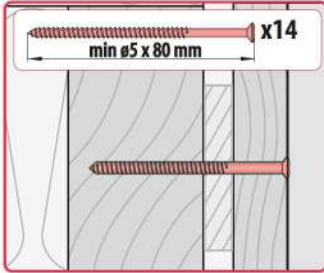
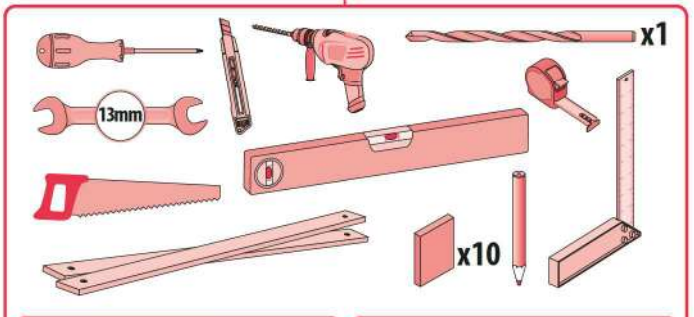



CZ	Montáž schodů a jejich použití je nutno provádět v souladu s montážním návodem a návodem k použití. Bezpečnost použití závisí na provedení všech činností uvedených v montážním návodu a na použití schodů v souladu se všemi body uvedenými v návodu k použití. Pozor! Použití schodů v rozporu s návodem je zakázáno, může způsobit vážnou nehodu a má za následek ztrátu záruky a odpovědnosti výrobce.
DE	Die Montage und Nutzung der Bodentreppe sollte gemäß der Anleitung durchgeführt werden. Die Bedienungssicherheit hängt davon ab, ob alle in der Montageanleitung genannten Tätigkeiten ausgeführt wurden und die Treppe nach allen in der Bedienungsanleitung angeführten Punkten benutzt wird. Achtung! Die Nichtbeachtung der Anleitung ist verboten und kann schwere Unfälle verursachen und ist aus der Garantie ausgeschlossen. Der Hersteller übernimmt keine Verantwortung.
EE	Pöönigulugu paigaldamine ja kasutamine peab toimuma vastavalt paigaldusjuhistele ja kasutusjuhendile. Kasutusohutus sõltub paigaldamisjuhistes näidatud kõigi toimingute rakendamisest ja pöönigulugu kasutamisest vastavalt kõikidele kasutusjuhendis toodud punktidele. Tähelepanu! Juhistele mitte vastav kasutamine on rangelt keelatud kuna võib põhjustada tõsise õnnetuse, see tühistab garantii ning muudab tootja toote eest enam mitte vastutavaks.
ES	El montaje y el uso de la escalera debe llevarse a cabo de acuerdo con el manual de instalación y el manual de uso de la misma. La seguridad de uso de la escalera depende de la correcta realización de todas las acciones indicadas en el manual de instalación y uso de la escalera de acuerdo con todos los puntos indicados en el manual de uso. ¡Precaución! Está prohibida la utilización de la escalera que no sea conforme con el manual de instrucciones, porque puede causar un accidente grave, deshabilita la garantía y hace que el fabricante no se responsabilice.
FI	Ullakkoportaiden asennus ja käyttö on suoritettava asennusohjeiden ja käyttöohjeiden mukaisesti. Ullakkoportaiden turvallinen käyttö edellyttää, että asennusohjeissa näytetyt toimenpiteet on tehty ja ullakkoportaita käytetään käyttöohjeita noudattaen. Varoitus! Jos ullakkoporrasta käytetään ohjeiden vastaisesti, saattaa se aiheuttaa vakavan onnettomuuden.
FR	Le montage et l'utilisation de l'escalier doivent être réalisés dans le respect de l'instruction de montage et d'utilisation. La sécurité d'utilisation dépend de la réalisation de toutes les activités indiquées dans l'instruction de montage et d'utilisation de l'escalier. Attention! L'utilisation des escaliers contrairement à l'instruction est interdite, elle peut provoquer un accident grave, annulation de la garantie et manque de responsabilité du fabricant.
GB	Installation and operation of the loft ladder must be carried out in compliance with the fitting instructions and user manual. Safety of use depends on the implementation of all actions shown in the fitting instructions and use of the loft ladder in accordance with all points shown in the user manual. Caution! Using the loft ladder in violation of the instructions is strictly forbidden, may result in a serious injury, will invalidate the Warranty and makes the Manufacturer no longer liable for the product.
HU	A padlásfeljáró lépcső beépítését és üzemeltetését a beépítési- és használati útmutatóban foglaltak szerint kell elvégezni! Az üzemeltetés biztonsága függ a beépítési útmutatóban feltüntetett valamennyi művelet elvégzésétől valamint a használati útmutató valamennyi pontjának betartásától. Figyelem! A padlásfeljáró lépcső útmutatóval ellentétben vagy azzal nem megegyező módon történő használat tilos és balesetveszélyes, illetve súlyos balesettel járhat valamint garanciavesztést eredményez; a fentiekből adódó következményekért a gyártó nem vállal semmiféle felelősséget.
IT	L'installazione e l'uso della scala devono essere eseguiti in conformità alle istruzioni di montaggio e le istruzioni d'uso. La sicurezza d'uso dipende dalla realizzazione di tutte le attività indicate nelle istruzioni di montaggio e dall'uso della scala in conformità a tutti i punti indicati nelle istruzioni d'uso. Attenzione! È assolutamente vietato l'utilizzo difforme alle istruzioni d'uso dato che può essere causa di gravi incidenti ed in ogni caso fa decadere la garanzia nonché qualsiasi responsabilità del produttore.
LT	Palėpės laiptų montavimas ir eksploatavimas turi būti atliekamas pagal montavimo ir naudojimo instrukciją. Naudojimo saugumas priklauso nuo visų veiksmų, nurodytų montavimo instrukcijoje, įgyvendinimo, ir palėpės kopečių naudojimo, vadovaujantis visais vartotojo vadove nurodytais nurodymais. Įspėjimas: naudotis palėpės laiptais paželdžiant instrukcijas griežtai draudžiama, nes tai gali sukelti rimtą nelaimingą atsitikimą, ir gamintojas turi teisę panaikinti garantiją ir nebeįsakyti už gaminį.
LV	Bēniņu kāpņu uzstādīšana un lietošana veicama atbilstoši montāžas instrukcijai un lietotāja rokasgrāmatai. Droša lietošana ir atkarīga no tā, vai precīzi ievērotas visas uzstādīšanas instrukcijas un kāpnes tiek lietotas atbilstoši visiem lietotāja rokasgrāmatā norādītajiem punktiem. Uzmanību! Kāpņu lietošana neatbilstoši instrukcijas prasībām ir stingri aizliegta, jo tā var izraisīt nopietnus nelaimis gadījumus, kā arī pārtrauc noteikto garantijas apkalpošanu un ražotāja atbildību par produktu.
NL	Voer de montage en het gebruik van de trap uit in overeenstemming met de montagehandleiding en de gebruiksaanwijzing. De gebruiksviligheid is afhankelijk van de uitvoering van alle handelingen uit de montagehandleiding en het gebruik van de trap in overeenstemming met alle punten uit de gebruiksaanwijzing. Let op! Gebruik van de zoldertrap is niet toegestaan wanneer deze niet conform de handleiding is gemonteerd. Dit kan gevaarlijke situaties veroorzaken. De garantie wordt in dit geval niet toegekend en de producent is niet verantwoordelijk voor de mogelijke gevolgen.
PL	Montaż i użytkowanie schodów należy wykonywać zgodnie z instrukcją montażu i instrukcją użytkowania. Bezpieczeństwo użytkowania zależy od wykonania wszystkich czynności wskazanych w instrukcji montażu oraz korzystania ze schodów zgodnie ze wszystkimi punktami wskazanymi w instrukcji użytkowania. UWAGA! użytkowanie schodów niezgodnie z instrukcją jest zabronione, może spowodować groźny wypadek, wyłącza gwarancję oraz powoduje brak odpowiedzialności producenta.
PT	A montagem e utilização das escadas devem ser realizadas de acordo com as instruções de montagem e instruções de utilização. A segurança na utilização depende da execução de todas as ações indicadas nas instruções de montagem e de uma utilização das escadas de acordo com todos os pontos indicados nas instruções de utilização. Atenção! O uso da escada violando as instruções é estritamente proibido, pois isso pode causar um acidente grave, anula a Garantia e torna o Fabricante não responsável pelo produto.
RO	Instalarea și utilizarea scării trebuie efectuate conform instrucțiunilor de montaj și manualului de utilizare. Siguranța utilizării depinde de punerea în practică a tuturor acțiunilor prezentate în instrucțiunile de montaj și de folosirea scării în conformitate cu toate punctele prezentate în manualul de utilizare. Atenție! Încălcarea acestor instrucțiuni este interzisă deoarece duce la pierderea garanției și poate provoca accidente grave. Producătorul nu își asumă răspunderea pentru evenimentele produse ca urmare a încălcării instrucțiunilor de instalare și utilizare a scării.
RU	Монтаж и эксплуатация лестницы должны проводиться согласно инструкциям по монтажу и эксплуатации. Безопасность эксплуатации зависит от выполнения всех правил, представленных в инструкции по монтажу и в инструкции по эксплуатации. Внимание! Неправильная эксплуатация лестницы может привести к несчастному случаю, отменить гарантию производителя и снять с него ответственность.
SI	Montažo in uporabo stopnic je potrebno izvajati v skladu z navodili za montažo in navodili za uporabo. Varnost uporabe je odvisna od izvedbe vseh postopkov naštetih v navodilih za montažo oziroma od uporabe stopnic v skladu z vsemi točkami zapisanimi v navodilih za uporabo. Opozorilo! Uporaba lestve podvozja v nasprotju z navodili je strogo prepovedana, saj lahko povzroči resno nesrečo, razveljavi garancijo in povzroči, da proizvajalec ne odgovarja več za izdelek.
SK	Montáž schodov a ich použitie je nutné prevádzkať v súlade s montážnym návodom a návodom na použitie. Bezpečnosť použitia závisí na prevedení všetkých činností uvedených v montážnom návode a návode na použitie schodov v súlade so všetkými bodmi uvedenými v tomto návode. Pozor! Používanie schodov v rozpore s návodom je zakázané, môže spôsobiť vážnu nehodu a má za následok stratu záruky a zodpovednosti výrobcu.
US	Installation and operation of the attic ladder must be carried out in compliance with the fitting instructions and user manual. Safety of use depends on the implementation of all actions shown in the fitting instructions and use of the attic ladder in accordance with all points shown in the user manual. Warning! Using the attic ladder in violation of the instructions is strictly forbidden as it may cause a serious accident, it voids the Warranty and makes the Manufacturer no longer liable for the product.

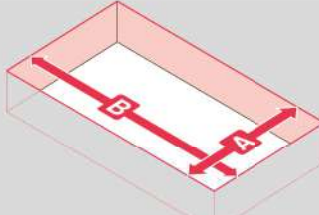

LWS LWK

1



LWS	H	cm	
A	x	B	cm
NR. ART. 			
info: www.fakro.com			
 - <input type="text"/> kg	 W = <input type="text"/> cm		
 - <input type="text"/> m ²	 L = <input type="text"/> cm		

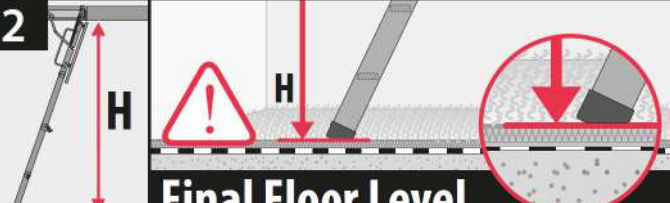

2



Final Floor Level

H	H _{min} 
280 cm	232 cm
305 cm	246 cm

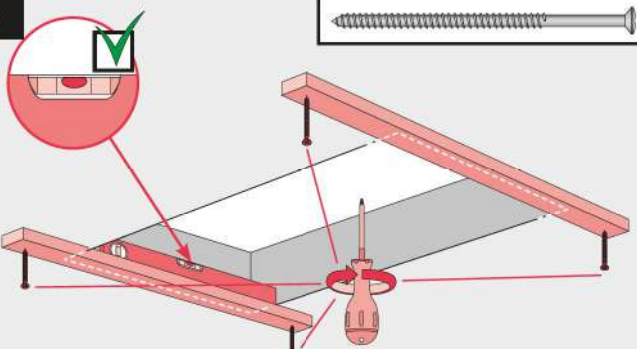
3

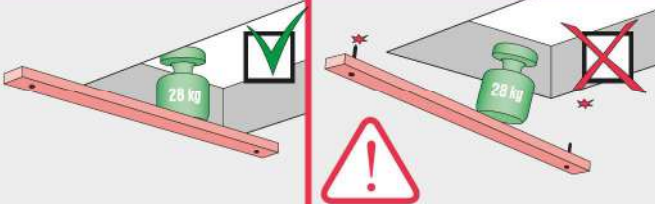

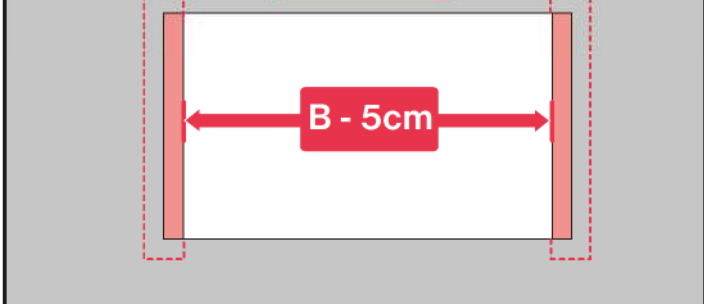

LWS LWK

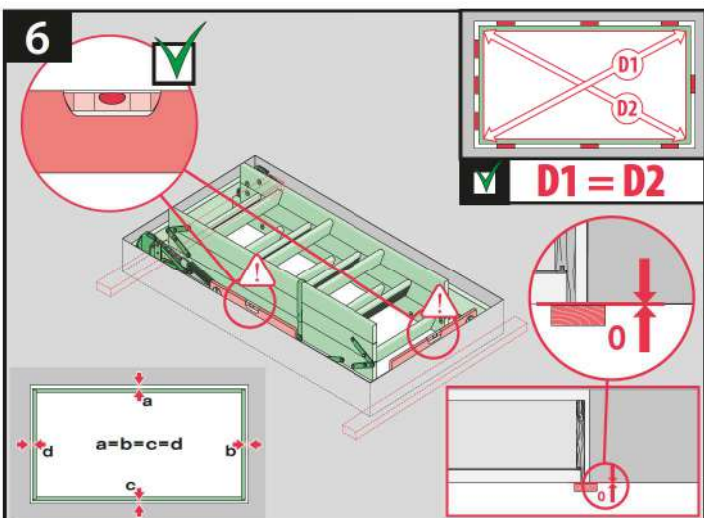
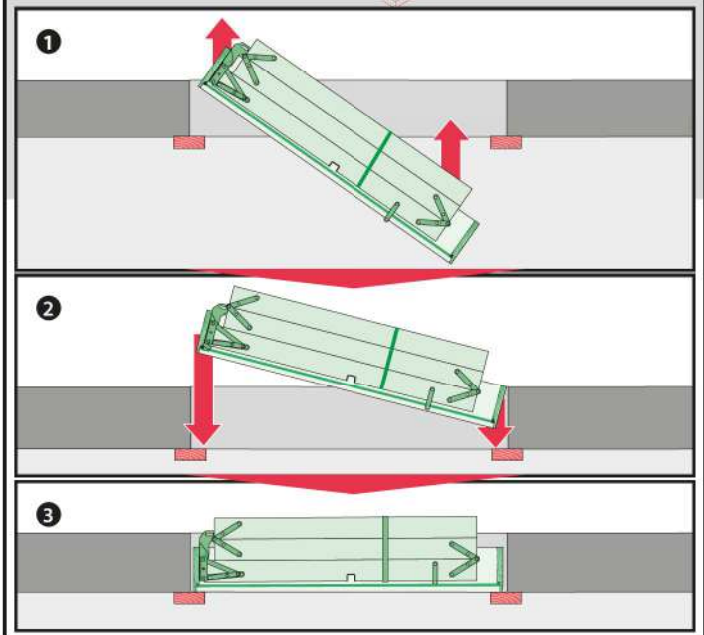
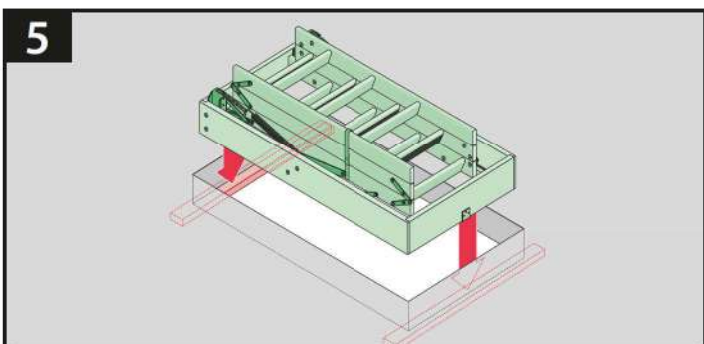
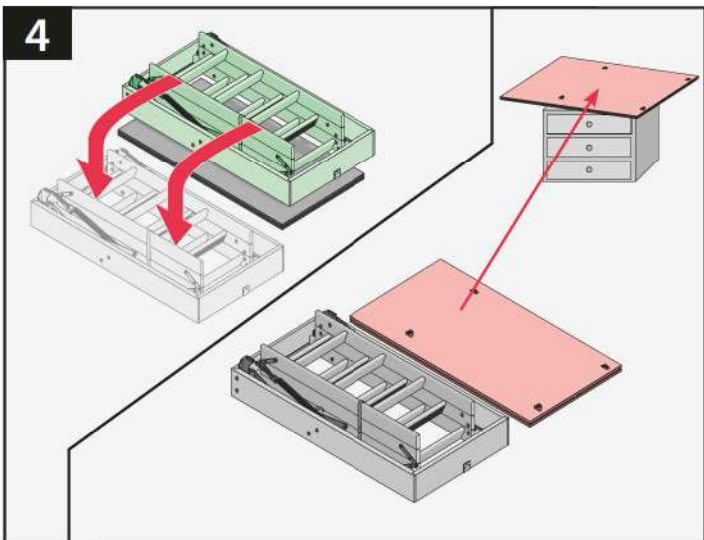

LWS LWK

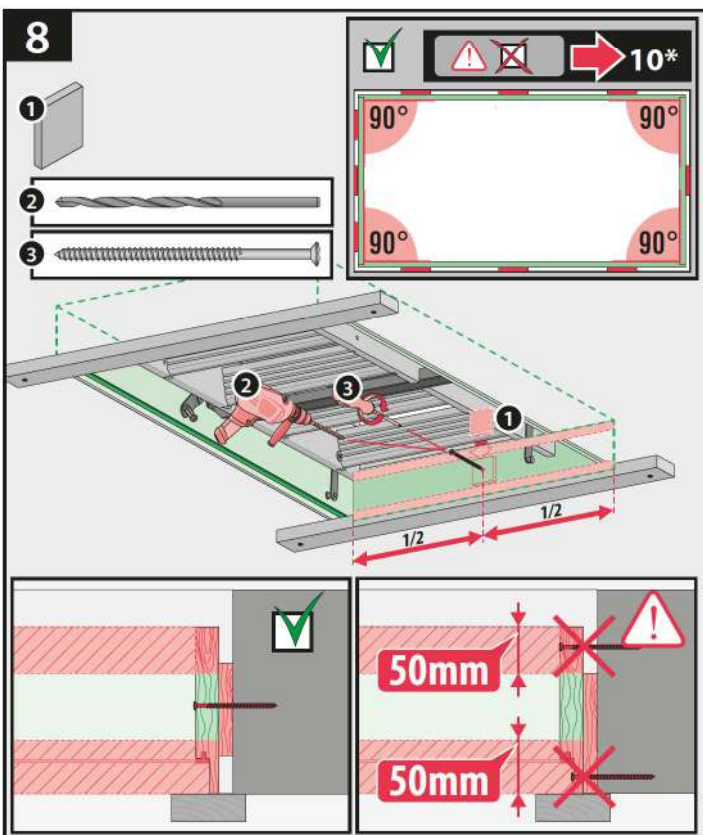
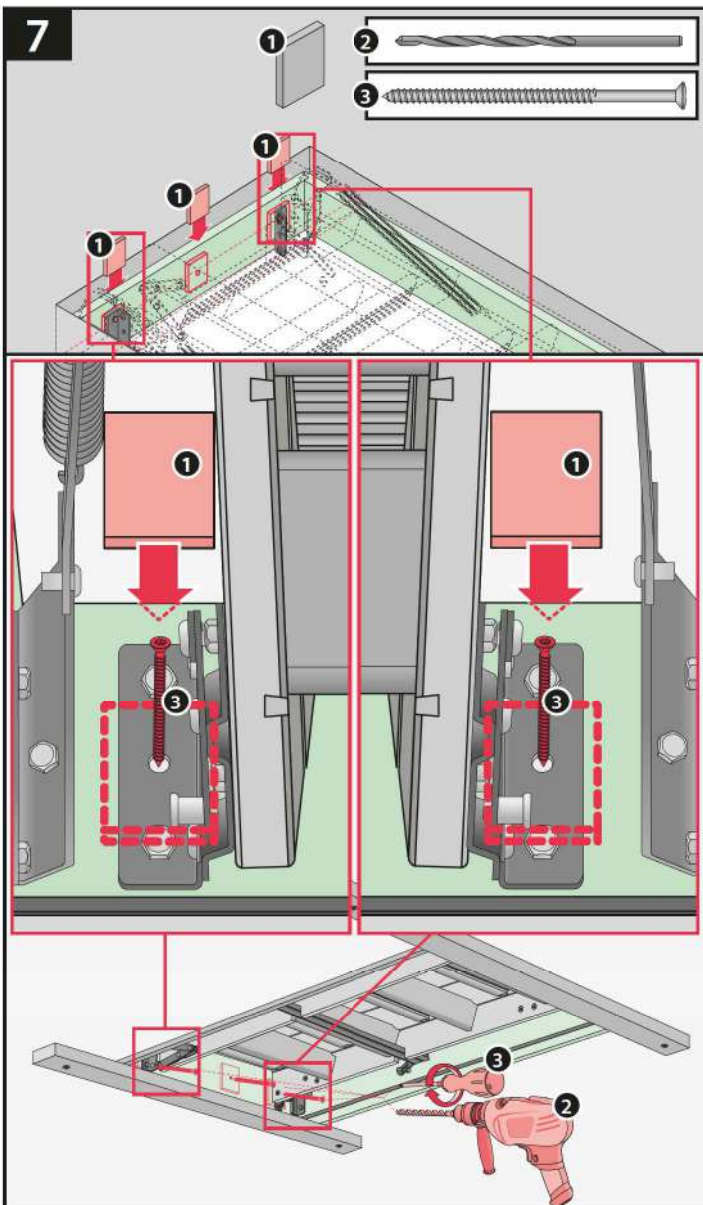

LWS LWK

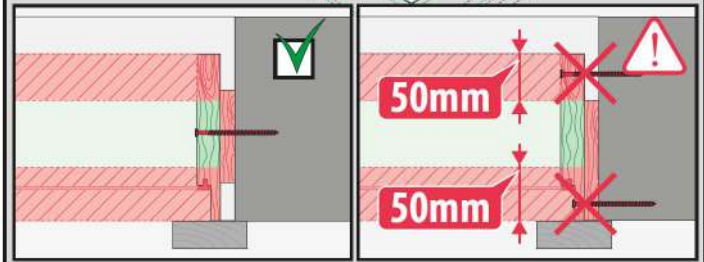
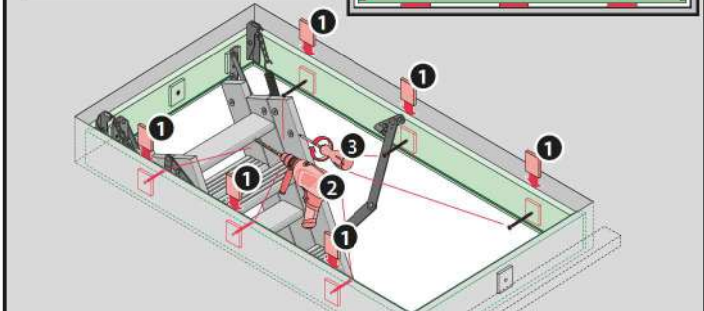
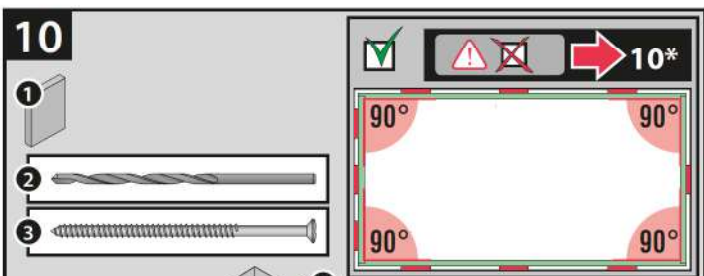
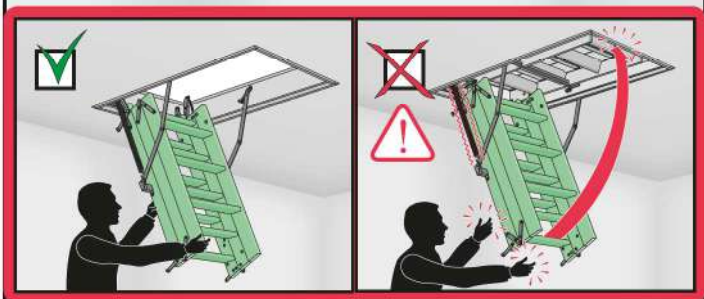
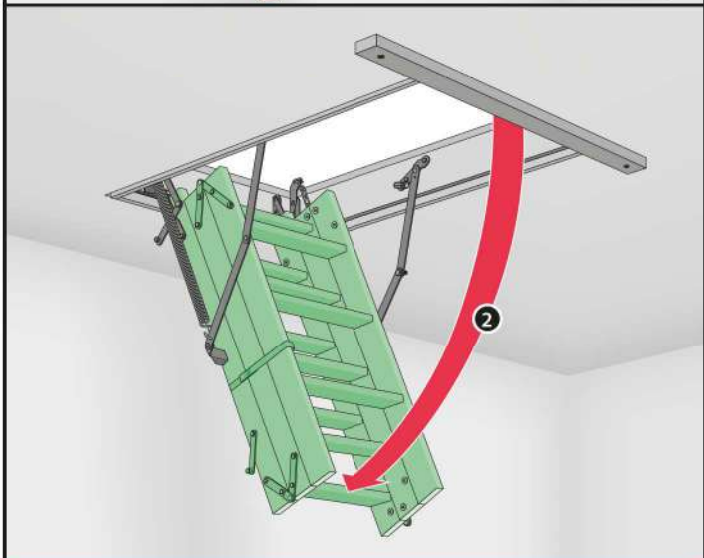
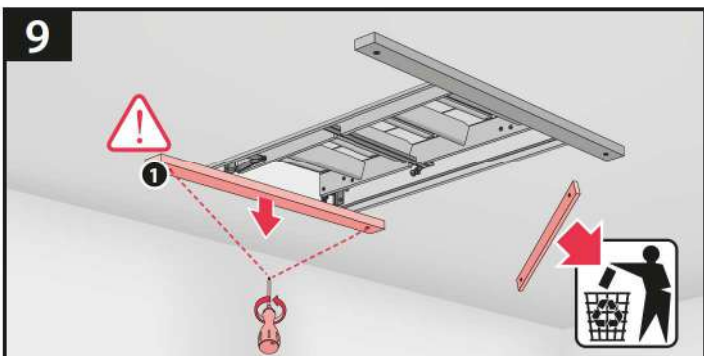

LWS LWK

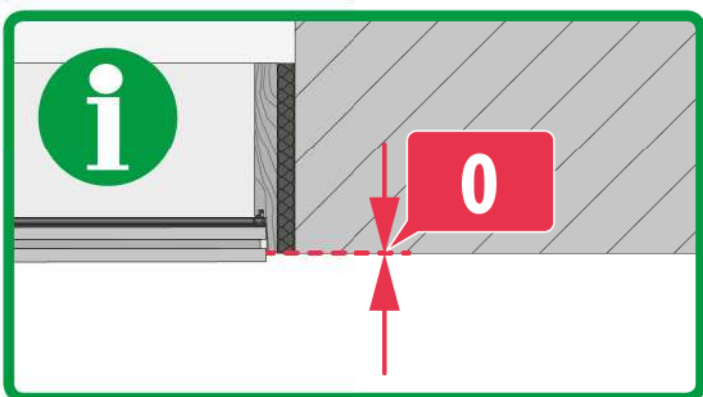
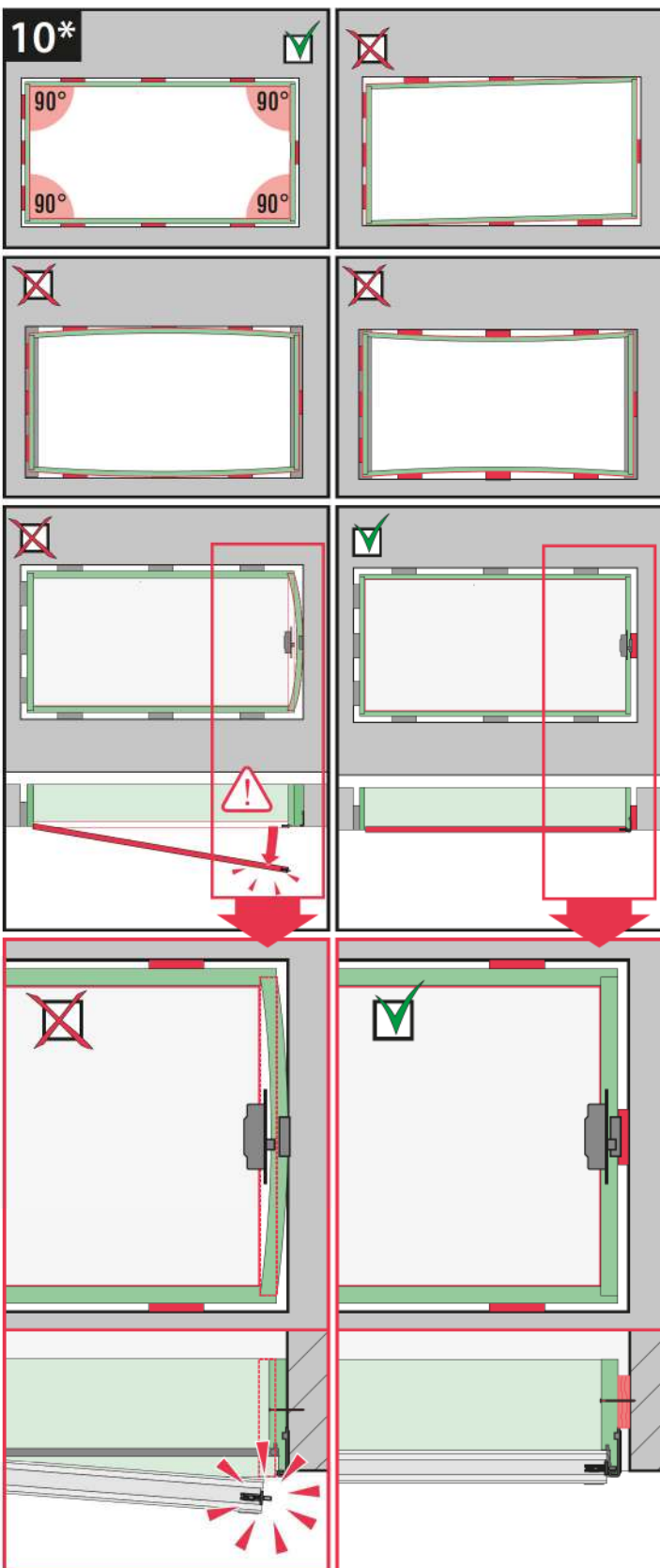

LWS LWK

12b

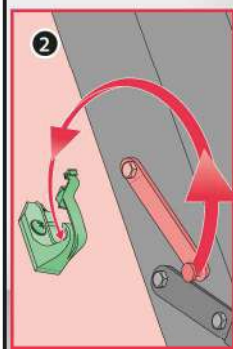
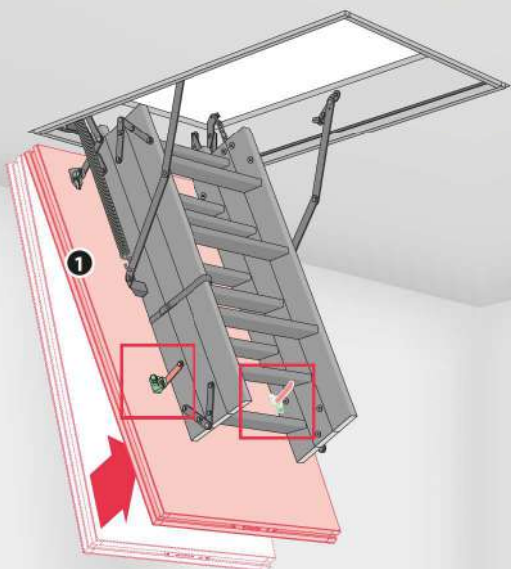

13

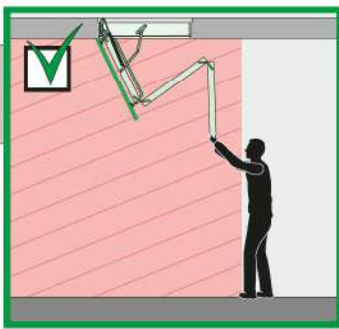
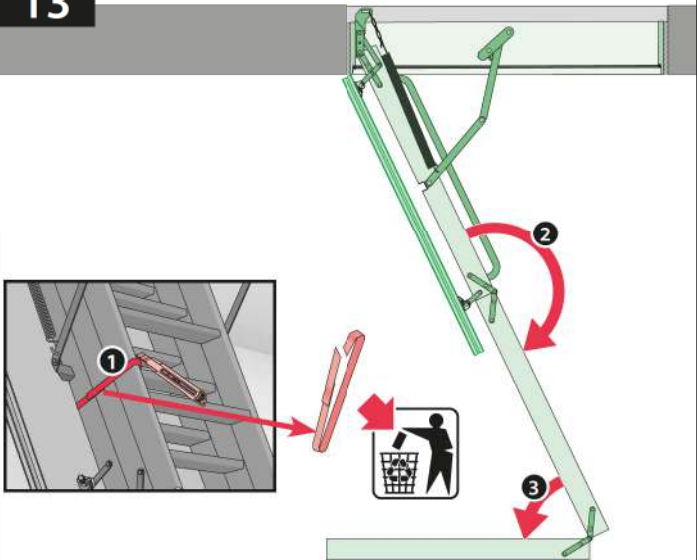

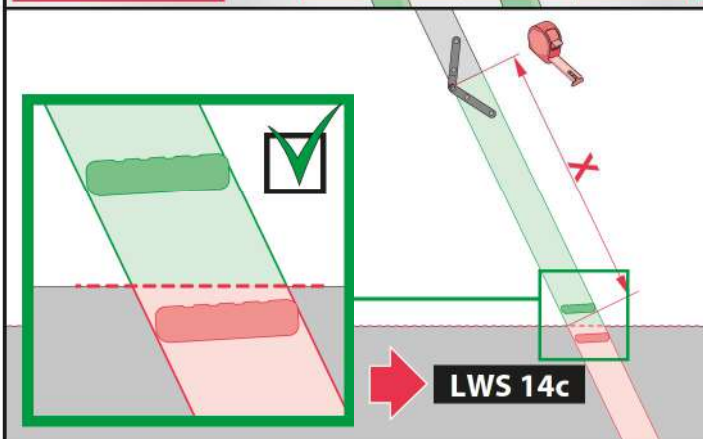
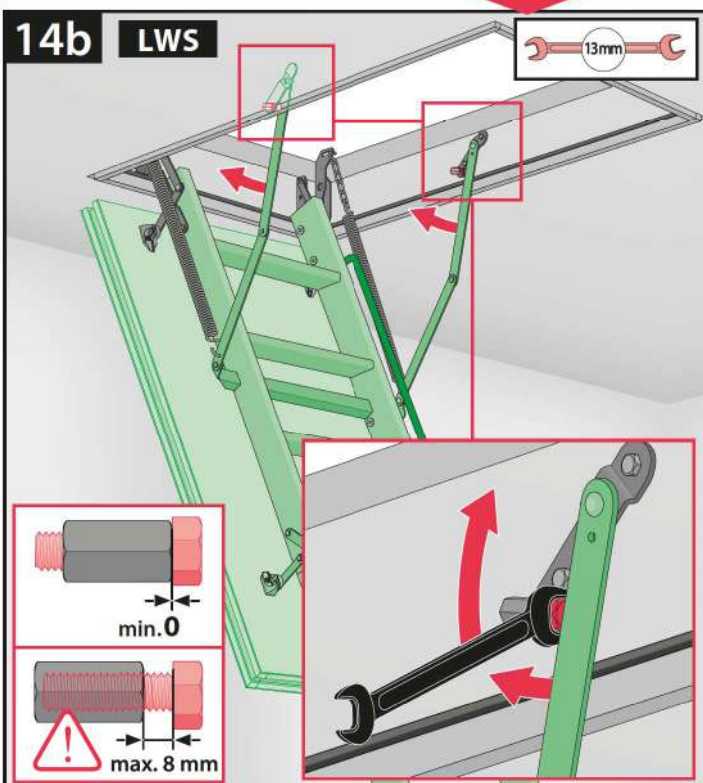
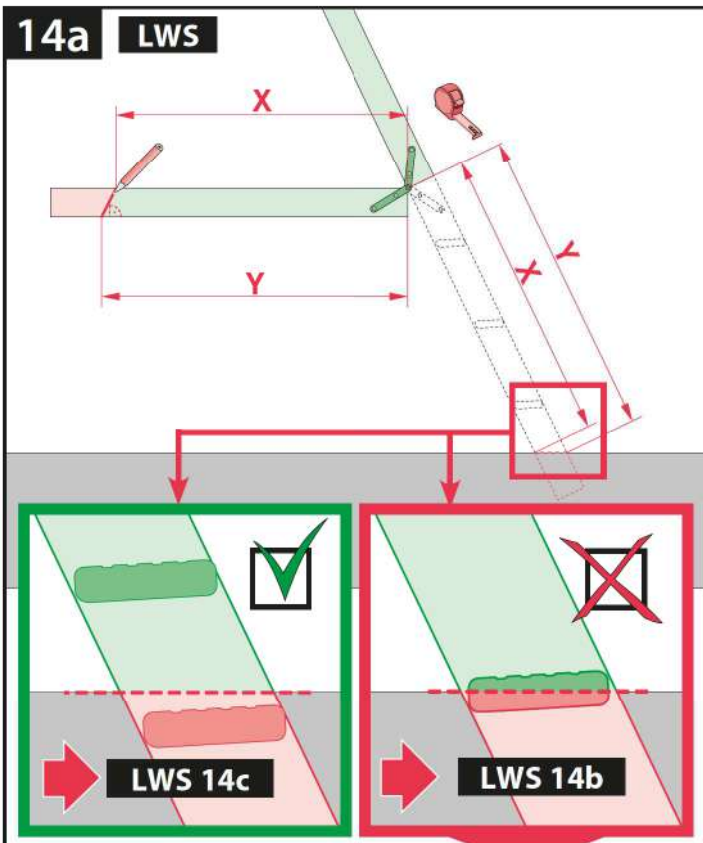

14c

LWS

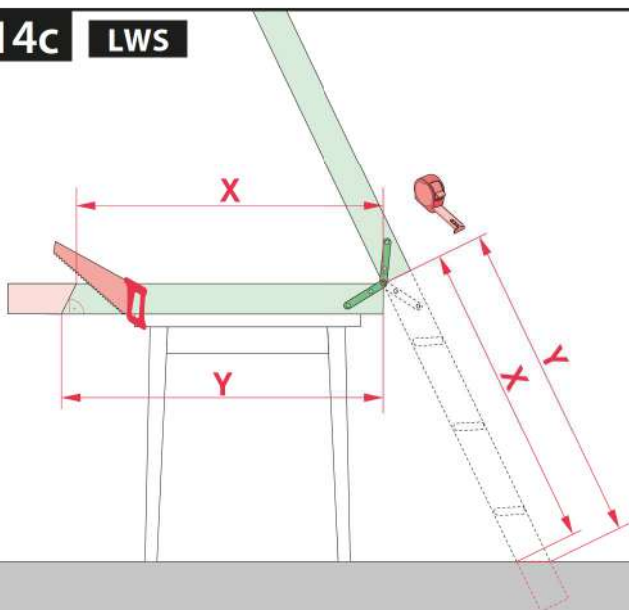

1

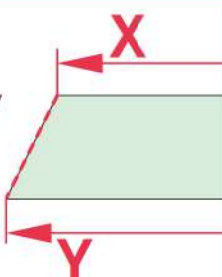

2

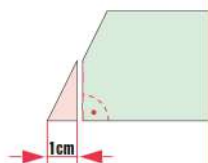

14a LWK

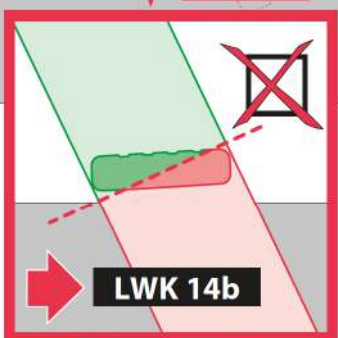
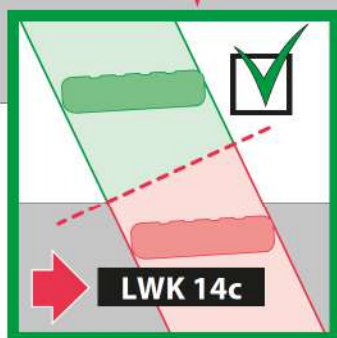
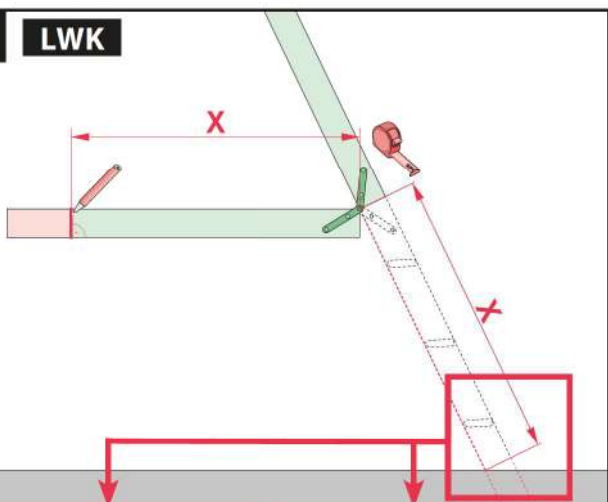

14b LWK

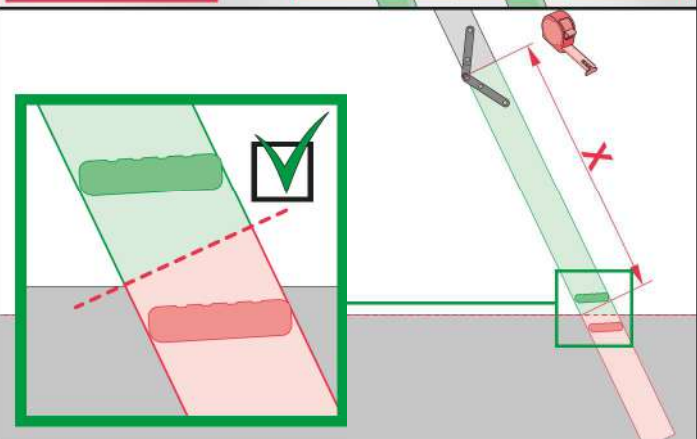
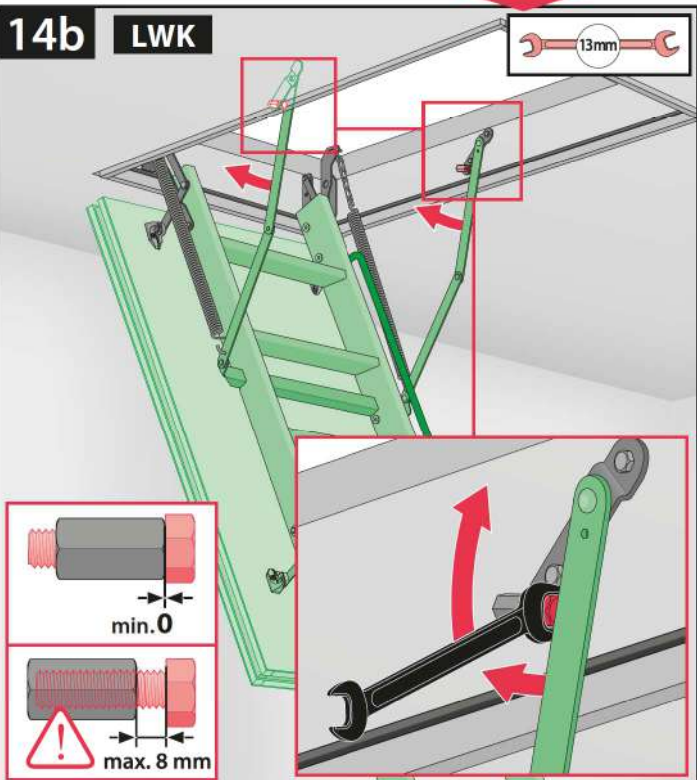

LWS LWK

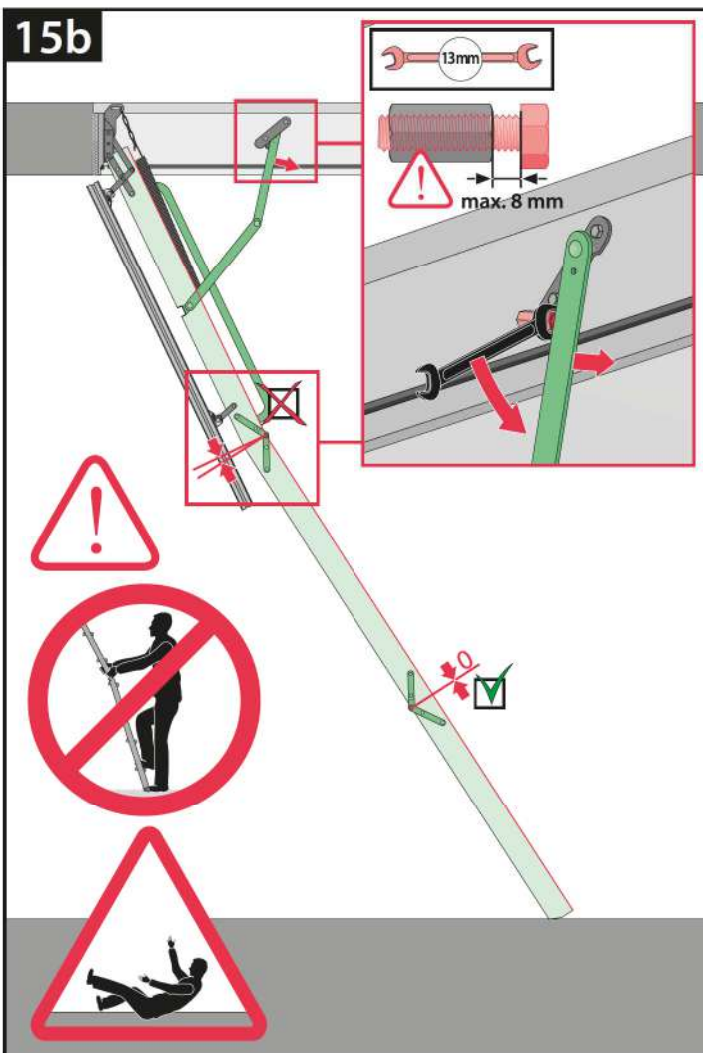
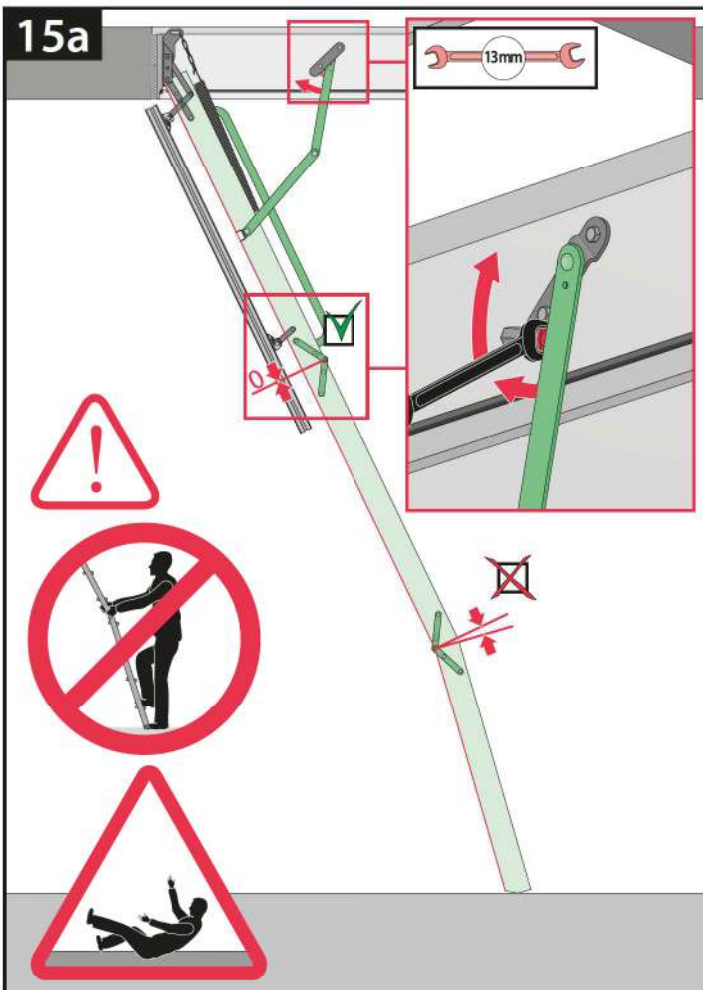

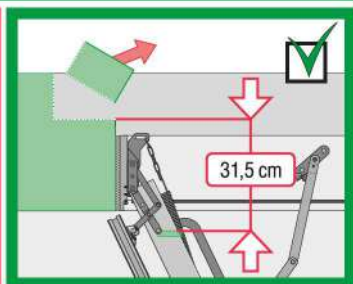
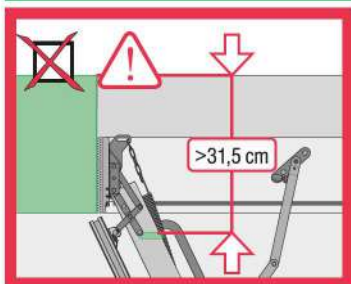
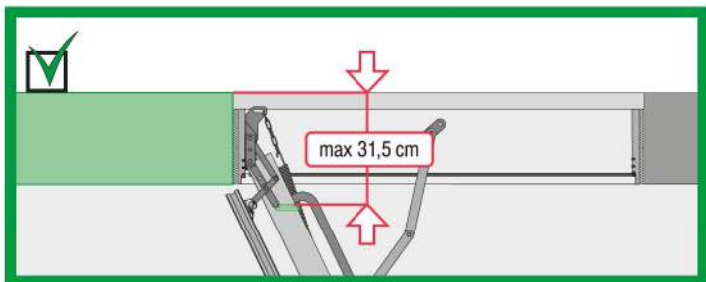

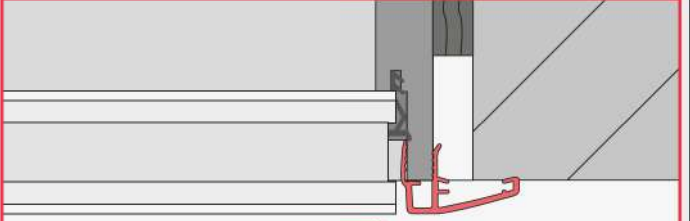
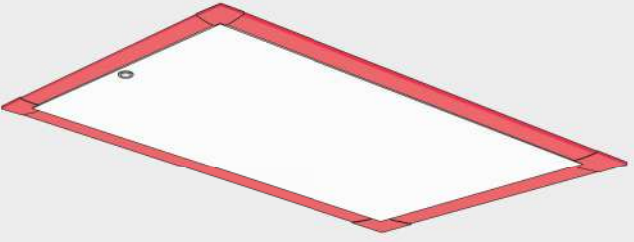

LXL-PVC

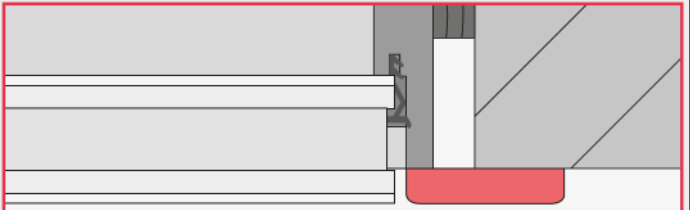
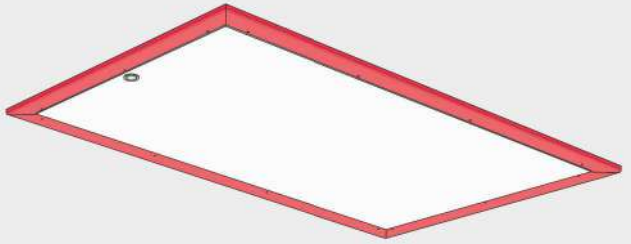

LXL-P/-W

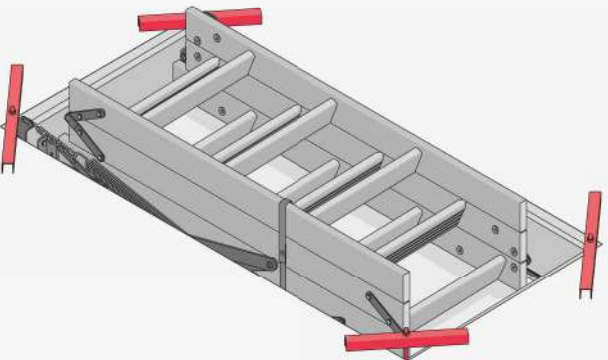

LXXK

! WARNING! - ACHTUNG! - UWAGA! - ATTENTION! - CUIDADO! - ВНИМАНИЕ!

**SAFETY! - SICHERHEIT! - BEZPIECZENSTWO!
SÉCURITÉ! - SEGURIDAD! - БЕЗОПАСНОСТЬ!**
<https://www.fakro.com/service/safety-instructions/>

**HYGRO
RH MAX
65%**

**FAKRO®
www.fakro.com**

**EN 14975
160kg
MAX**



<p>BG Производител и Продавач не носят отговорност за неспазване на съответните закони, изчисления и/или правила и вълнения за безопасност на поддръжката на продукта, архитектура, монтажника или собственика на сградата.</p> <p>CZ Výrobce ani prodejce nenesou žádnou odpovědnost za nedodržení příslušných platných zákonů, stavebních předpisů a bezpečnostních požadavků uživatelem výrobku, architektem, montážníkem nebo vlastníkem budovy.</p> <p>DE Hersteller und Verkäufer übernehmen keine Haftung für Nichtbeachtung entsprechender Rechts- und Bauvorschriften sowie Sicherheitsanforderungen seitens Produktbenutzers, Architekten, Monteure oder Gebäudebesitzers.</p> <p>ES El fabricante y el vendedor no tienen ninguna responsabilidad por el incumplimiento de la ley vigente, normas de construcción y exigencias de seguridad por parte del usuario del producto, arquitecto, instalador o el propietario del edificio.</p> <p>FR Le fabricant et le revendeur ne prend aucune responsabilité de ne pas respecter les lois applicables, les règlements sur les bâtiments et les exigences de sécurité par l'utilisateur du produit, l'architecte, l'installateur ou le propriétaire du bâtiment.</p> <p>GB Manufacturer and Seller shall bear no liability for failure to comply with the applicable laws, building codes and safety requirements by the user of the product, architect, fitter or owner of the building.</p> <p>HU A Gyártó és a Forgalmazó nem vállal semmilyen felelősséget a vonatkozó törvényi, építészeti és biztonsági előírások betartásának, építész, beépítőmester vagy építésmunkások által be nem tartásáért.</p>	<p>IT Il Produttore e il Rivenditore non potranno essere ritenuti responsabili per il mancato rispetto, da parte dell'utente del prodotto, dei progettisti, dell'installatore o del proprietario dell'edificio, delle leggi vigenti, nonché dei regolamenti edilizi e di quelli relativi alla sicurezza.</p> <p>NL De fabrikant en verkoper zijn niet aansprakelijk voor gevolgen bij het niet opvolgen van toepasselijke wetten, bouwvoorschriften en veiligheidsvoorschriften door de gebruiker van het product, de architect, de installateur of de eigenaar van het gebouw.</p> <p>PL Producent i Sprzedawca nie ponosi żadnej odpowiedzialności za nieprzestrzeganie stosownych przepisów prawa, przepisów budowlanych i wymogów bezpieczeństwa przez użytkownika produktu, architekta, montażystę lub właściciela budynku.</p> <p>PT O fabricante e o vendedor não tem nenhuma responsabilidade pelo não cumprimento da lei, códigos de construção e as exigências de segurança por parte do usuário do produto, arquiteto, instalador ou proprietário do edifício.</p> <p>RO Nu producătorul, nici distribuitorul nu își vor asuma răspundere de răspundere pentru nerespectarea legilor în vigoare, a legilor din domeniul construcțiilor sau a măsurilor de siguranță impuse utilizatorilor produsului, arhitecților, montajistilor sau proprietarilor clădirii.</p> <p>RU В случае несоблюдения архитектором, монтажником или владельцем здания строительных правил и норм безопасности ответственность с производителя и продавца снимается.</p> <p>SK Výrobca a predajca nenesú žiadnu zodpovednosť za nedodržanie príslušných ustanovení zákona, stavebných predpisov a bezpečnostných požiadaviek užívateľom výrobku, architektom, montážnikom alebo majiteľom objektu.</p>
---	--